

Thermistor Room Temperature Sensor

THERMISTOR ROOM TEMPERATURE SENSOR



Description

The TB/TS Thermistor Temperature Sensor is a wall-mounted thermistor room temperature sensor in a low-profile enclosure designed for good thermal response. It has several options including a low-profile adjustment knob (e.g. setpoint trim), a pushbutton (e.g. occupancy override), two LEDs (e.g. occupancy status indication), and a 5 way switch (e.g. fan control). These options are available in various combinations.

Features

- Surface fitting or fits on standard pattress
- Optional low profile adjustment knob (1 to 11 k Ω)
- Optional override button and status LEDs.
- Optional fan control switch (off, low, medium, high, automatic)

Physical

e.g. TB/TS/KOSF

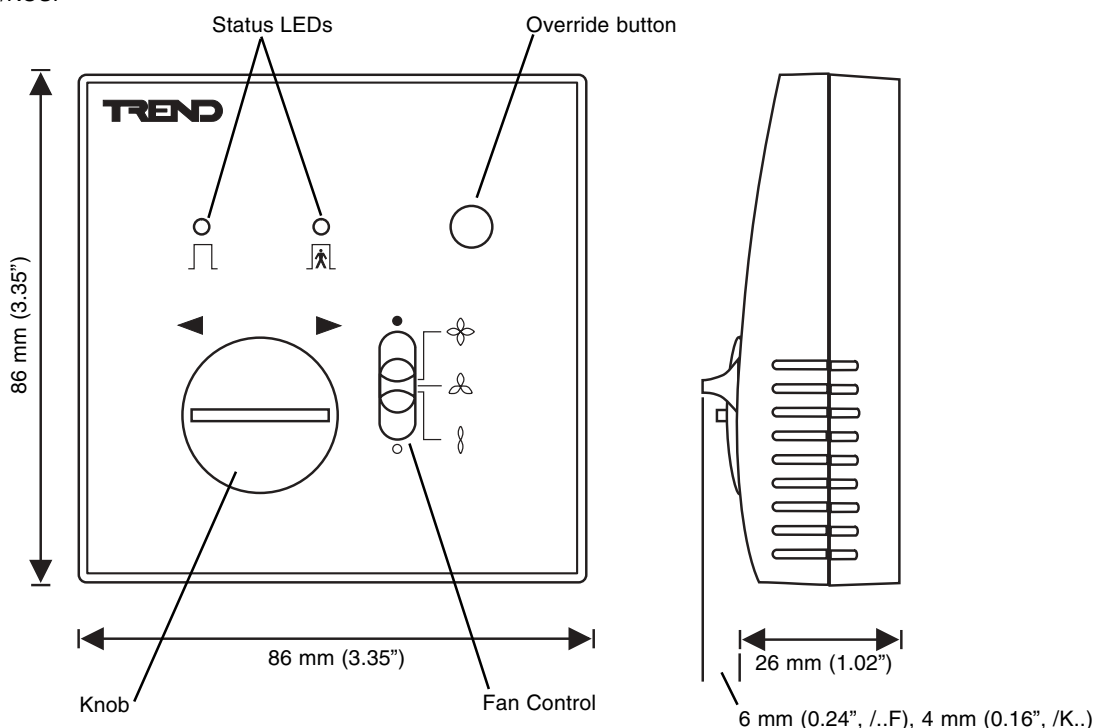

FUNCTIONALITY

Housing

The TB/TS is suitable for mounting in a wall, and can either be mounted on a standard pattress or mounted on a flat surface.

TB/TS

The basic TB/TS sensor provides a standard Trend thermistor sensing element (10 kΩ at 25 °C, 77°F) for space temperature measurement. There are options for Knob input, Override button input, Status Indication output, and Fan Control input.

There are three structural variants, the variant being used depends on the option set selected:

Two terminals: TB/TS

Half board with 3 terminals: TB/TS/K

Full board with 6 terminals: TB/TS/OS, /KO, /KOS, /KOF, /KOSF, /KE, /KEF

The adjacent schematic diagram illustrates the full complement of options. The TB/TS uses 2 unidentified terminals as polarity is unimportant, the TB/TS/K uses the half board with a 3 terminal connector, and all the other options use the full board with a six terminal connector.

Factory set links are fitted to the full board which sets the board use for either IQ, or IQL use. The TB/TS/OS, /KO, /KOS, /KOF, /KOSF are linked for IQ use whereas TB/TS/KE, and /KEF are linked for IQL

Knob option, /K

The knob option, /K, gives a 1 to 11 kΩ potentiometer variable resistance. The minimum resistance of 1 kΩ eliminates the sensor module producing an 'Out of Limits' alarm as the controller thermistor input reads 0 V. (This is normally used to detect faulty thermistors).

Override button option, /O (IQ), /E (IQL)

The override option allows the occupancy status of the area to be toggled or extended manually. For IQL controllers the status level detector and LED circuitry is not fitted to the TB/TS board, and the links isolate terminal 5, so that the override button provides a contact closure between terminals 4 and 5.

For IQ controllers the button does not require any dedicated wiring as it operates by open circuiting the knob wiring for approximately seven seconds. However, this means that the knob output must always be wired even for the /OS option which does not have a knob. Similarly, the override option pulse generator is powered via terminal 4 (Status/Power), so it is also connected for /KO or /KOF options. For IQs, connect to 10 Vdc or 24 Vdc; if the sensor has status indication fitted but not used (/KOS, /OS, /KOSF used as /KO or /KOF), the input should be powered from 10 Vdc (e.g. from dummy analogue output for IQs). The override implementation can be achieved by the IQ control strategy shown. This differentiates between the operation of the push button and a circuit problem in the adjustment knob. The 'Out of Limits' alarm of the input sensor (S2) is used to detect the open circuit condition and this alarm should not be enabled or the alarm will be generated with each operation of the override button. The sequencing order of the sensor and the three logic modules is important as the strategy checks for the 'Out of limits' alarm bit of S2 (IQ2 bit 42,2) returning to zero one sequence step after it went into alarm. The output of the strategy is a five second pulse at node 21,2 which can be used within a larger strategy. A further logic module G4 can be used to latch this pulse and generate an occupation status. The gate module is used to avoid the open circuit knob value being passed through to subsequent modules by latching the previous value while the sensor is in alarm.

Note that S2, G2, G3, G1 need to be sequenced 3 times on the IQ151+ at equal spacing.

Status indication option, /S

An IQ control strategy is shown. The status indication is driven from pin 4. When the voltage output from the IQ is between 4.5 V and 5 V, the 'unoccupied', yellow LED is illuminated, and when it is above 5.5 V the 'occupied' green LED is illuminated. A function module F2 may be used to select the correct voltage as shown. The output of G4 from the override strategy may be used to select the appropriate status via the function module F2. Pressing the override button causes the selected LED to pulse for about 7.5 seconds. After this period the selected LED will return to steady illumination. This indicates that the button has been pressed and allows time for the IQ strategy to change the output to the status LEDs and select the other LED.

Thus normally the operator will press the button, the current LED will flash and when the strategy has operated (after 5 seconds) the other status LED will be illuminated to confirm the occupancy status change.

TB/TS schematic diagram

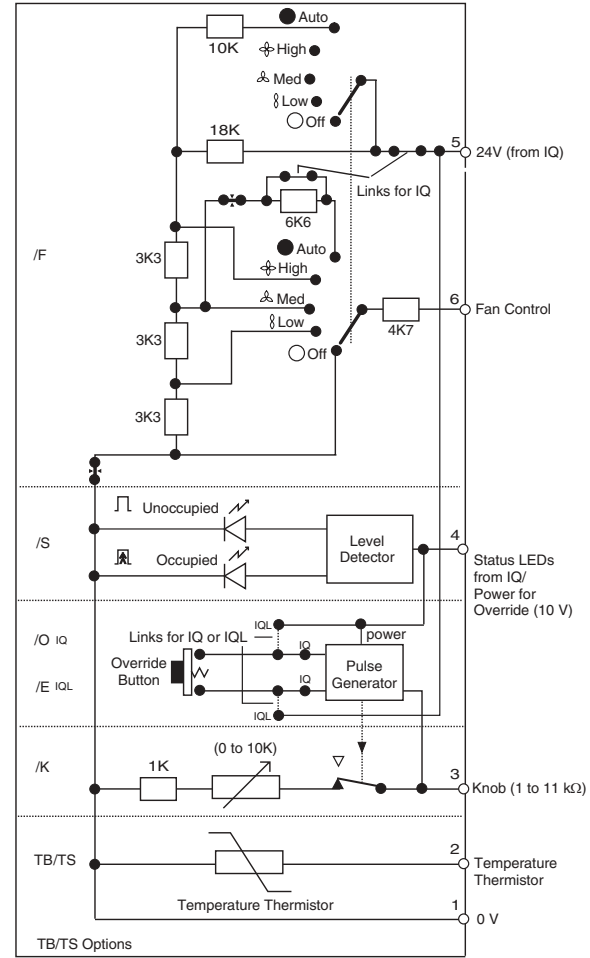

IQ Override Strategy

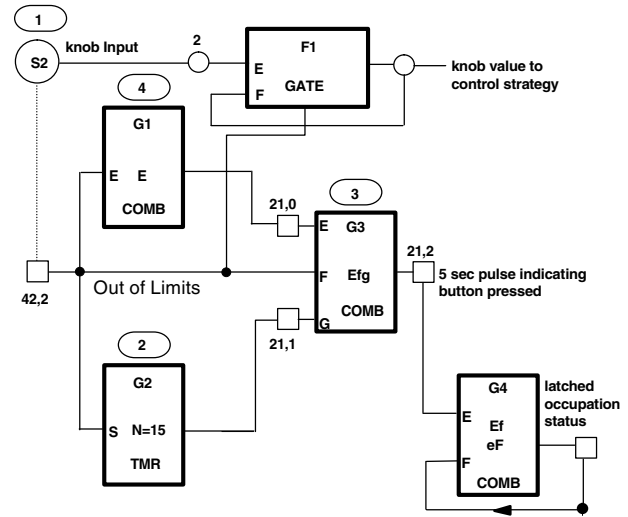

IQ Status Indication Strategy

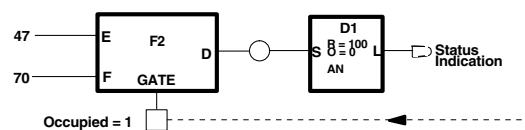

Note that the nodes only apply to pre-IQ3xcite strategies

FUNCTIONALITY (continued)

Fan Control option, /F

This switch provides either a stepped variable resistance, or a stepped variable voltage corresponding to five switch positions. The fan control produces a voltage signal for an IQ controller analogue voltage input between terminals 1 (0V) and 6 with terminal 5 connected to 24 V. If the board is linked for IQL then a set of different switched resistances is produced between terminals 1 and 6.

The voltage and resistance levels corresponding to the five switch positions are shown in the adjacent table:

Switch Position	TB/TS/ version	Voltage		Resistance
		Nominal	Recommended	
Legend	Terminals:	1 (0V) to 6, 5 (24V)		1 to 6
	Fan Off	0V		4K7 ohms
	Fan low speed	2.8V	>2 V	8K0 ohms
	Fan medium speed	5.6V	>4.5 V	11K3 ohms
	Fan high speed	8.5V	>7 V	14K6 ohms
	Automatic	9.7V	>9 V	17K9 ohms

Note that the IQ recommended limits may need to be changed to suit mains supply voltage and auxiliary supply loading, or a 24 Vdc regulated supply can be used.

INSTALLATION

Choose location
Mount sensor (via two screws - minimum)
Connect terminals

Assemble sensor unit
Setup Strategy
Test

For full installation details see TB/TS Installation Instructions TG200604, TB/TS/K Installation Instructions TG200607, TB/TS/KO, /OS, /KOS, /KOF, /KOSF Installation Instructions TG200606, TB/TS/KE, /KEF Installation Instructions TG200605

CONNECTIONS

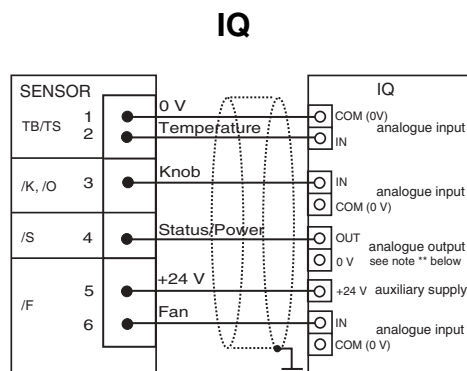
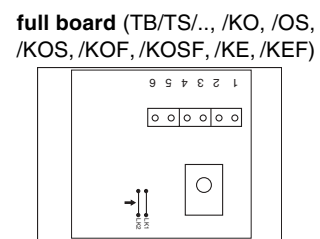
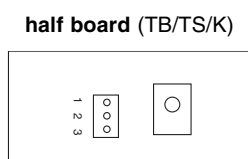
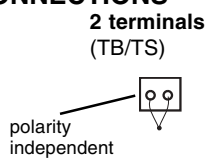

OPTION	CONNECT TERMINALS
TB/TS	1, 2
TB/TS/K	1, 2, 3
TB/TS/KO***	1, 2, 3, 4**
TB/TS/OS***	1, 2, 3*, 4
TB/TS/KOS***	1, 2, 3, 4
TB/TS/KOF***	1, 2, 3, 4**, 5, 6
TB/TS/KOSF***	1, 2, 3, 4, 5, 6

Asterisked notes relating to IQ table:

*Note that the override function operates via the knob connection so that for the /OS option, the Knob connection must be made.

**Note that the override function takes its power from the Status/Power connection so the Status/Power connection (terminal 4) must also be made for /KO and /KOF versions. For these /KO and /KOF versions, connect the Status/Power. For IQs, connect to 10 Vdc or 24 Vdc, but if status indication is fitted but not used (/OS, /KOS, /KOSF used as /KO or /KOF), 10 Vdc must be used e.g. from dummy analogue output.

***Note that /KO, /OS, /KOS, /KOF, /KOSF cannot be used by IQ212 (although they can be used by IQ211)

IQL	OPTIONS
IQL10, 12, 14	TB/TS
IQL11, 17	TB/TS, TB/TS/K, TB/TS/KE
IQL13	TB/TS, TB/TS/K, TB/TS/KE, TB/TS/KEF
IQL15	TB/TS, TB/TS/K, TB/TS/KE, TB/TS/KEF
IQL16	TB/TS, TB/TS/K

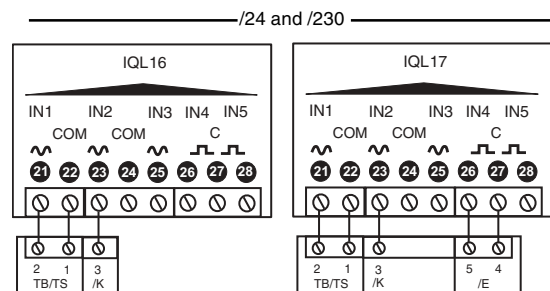
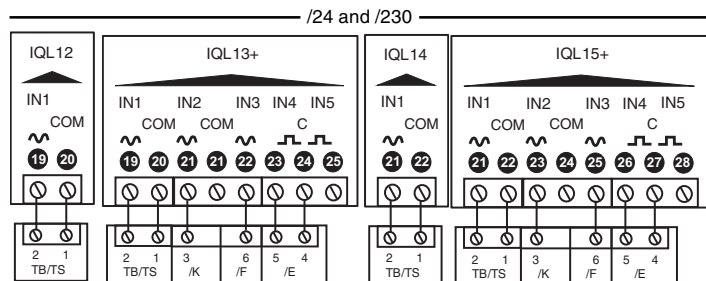
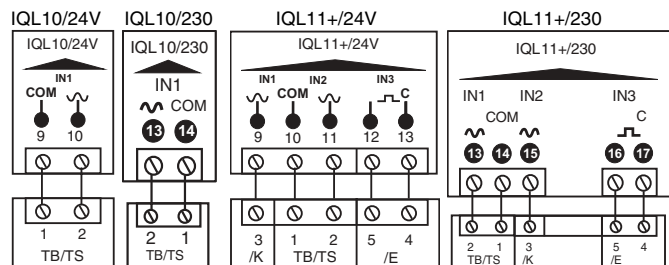

PRODUCT CODES

TB/TS/[OPTIONS] :thermistor temperature sensor with options as shown in table. Consists of 2 parts (front panel, and backplate) for either flush mounting or mounting on a standard pattress.

Valid variants:

- TB/TS TB/TS/KOSF
- TB/TS/K TB/TS/KE
- TB/TS/KO TB/TS/KEF
- TB/TS/OS TB/TS/BOX 20 :Box of 20 sensors
- TB/TS/KOS TB/TS/K/BOX20 :Box of 20 sensors
- TB/TS/KOF

[OPTION]	Description
blank	Thermistor Temperature sensor only
K	1 to 11 kohm adjustment knob (e.g. setpoint trim)
O	Pushbutton (e.g. occupancy override); open circuits knob wiring
E	Pushbutton (e.g. occupancy override); volt free contact closure
S	Status LEDs - two LEDs (e.g. indicating occupied/unoccupied)
F	Fan speed select input to give off, low speed, medium speed, high speed, or automatic, either by stepped voltage or switched resistance values

SPECIFICATIONS

Electrical

- Connection :1 part screw terminals for 0.5 to 2.5 mm² cross section area (14 to 20 AWG) cable. 2 terminals for TB/TS, 3 for TB/TS/K, and 6 for all other options.
- Thermistor :10 kΩ @ 25 °C (77 °F)
- Temperature range :0 to +40 °C (recommended).
- Temperature Accuracy :of sensor, ±0.3 °C, ±0.54 °F(0 to +40 °C, 32 to 104 °F)
- Potentiometer :1 kΩ to 11 kΩ ±20 %.
- Override :7s duration pulse (open circuits knob input).
- /O :volt free contact closure
- /E :voltage free contact closure
- Status LEDs :Occupied green LED 5.5 V to 10 V, Unoccupied yellow LED 4.5 V to 5.0 V.
- Fan Control :5 level switched voltage (0 V to 9.7 V).
- for IQ :5 level switched resistance 4.7 kΩ to 17.9 kΩ (TB/TS/KEF only).
- for IQL

Input channels and sensor scaling (continued)

Thermistor

Link input channel for thermistor, T; use sensor type scaling mode 5, characterise, with the input type set to 1 (thermistor volts) and the table below:

Y	Input type	1 (thermistor volts)	
E	Exponent	3	
U	Upper	110	
L	Lower	-40	
P	Points	6	
x	Ix	Ox (°C)	Ox (°F)
1	2.648	49.9	121.8
2	3.475	39.9	103.8
3	4.462	30	86
4	6.656	10	50
5	7.656	0	32
6	8.33	-8	17.6

System Accuracy

(including controller)

- :±0.8 °C, ±1.4 °F (0 to +40 °C, 32 to 104 °F)

Fan Control

Link input channel for voltage, V; use sensor type scaling mode 5, characterise, with the input type set to 0 (volts) and the table below (this produces the input in the range 0 to 9.7):

Y	Input type	0 (volts)
E	Exponent	2
U	Upper	10
L	Lower	0
P	Points	2
x	Ix	Ox
1	0	0
2	10	10

Input channels and sensor scaling

IQLs have pre-configured strategies. For IQ controllers the input channels must be set up correctly and the sensor type modules must be set up with the correct scaling. SET is recommended to simplify the setting of sensor type modules. The following SET unique sensor references should be used:

- Knob: **Knob TB 3 deg trim** (guaranteed ±3 trim) alternatively: **Knob T 3 deg trim** (±3 ±20% linear trim)
- Thermistor: **Trend Thermistor (20 points)**
- Fan control: **Fan Control V**

If not using SET, use the following tables for all IQ2 series controllers with firmware of version 2.1 or greater; for all other IQ controllers see the Sensor Scaling Reference Card, TB100521A.

Knob

Link input channel for thermistor, T; use sensor type scaling mode 5, characterise, with the input type set to 3 (Kohms) and the table below (this produces a guaranteed trim of -3 to +3):

Y	Input type	3 (Kohms)
E	Exponent	1
U	Upper	3.2
L	Lower	-3.2
P	Points	4
x	Ix	Ox
1	.95	-3.1
2	1.05	-3
3	8.95	+3
4	13.05	+3.1

Mechanical

- Flush fitting :86 mm (3.35") x 86 mm (3.35") x 26 mm (1.02").
- Enclosure Material :Flame retardant (V0) ABS.
- Environmental :-10 °C (14 °F) to +50 °C (122 °F) 0 to 90 %RH non-condensing.

Trend Control Systems Ltd reserves the right to revise this publication from time to time and make changes to the content hereof without obligation to notify any person of such revisions or changes.

